



TEC SYSTEM



MI

**TURBO MIXEUR & INJECTEUR
POUR PETITS CHANTIERS,**

**TURBO MIXER & GROUTER
FOR SMALL JOB SITES.**

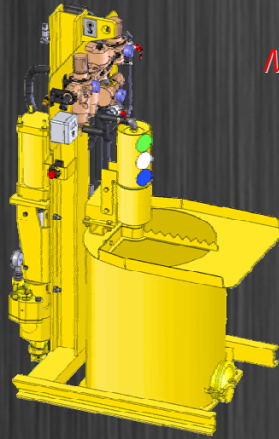

MI 100 P

Sur skid / on skid :

L : 1 200 mm
W : 700 mm
H : 1 800 mm
P : 280 daN

Sur roues / on wheels :

L : 1 300 mm
W : 1 000 mm
H : 1 950 mm
P : 340 daN

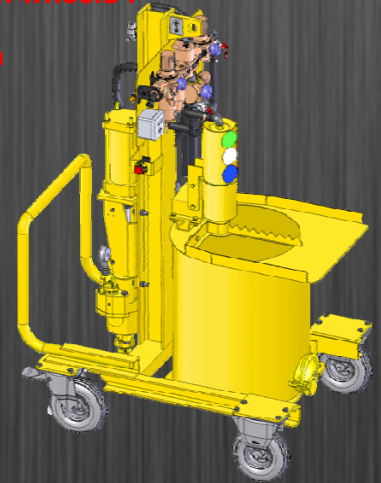

MI 120 E PH5

L : 2 100 mm
W : 1 700 mm
H : 1 400 mm
P : 1 400 daN

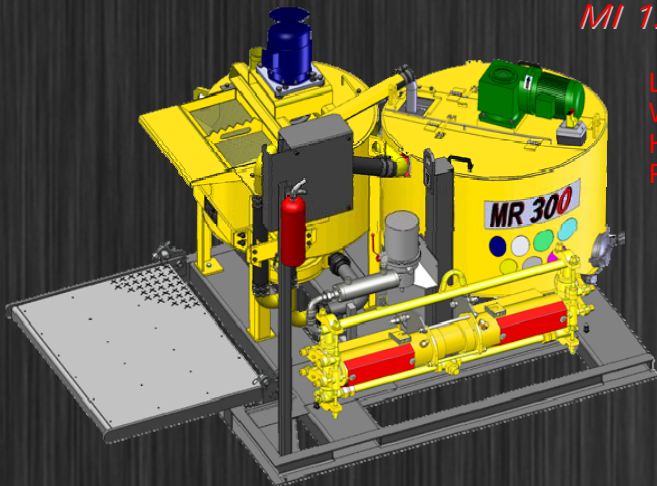

Pneumatiques, électriques ou diesel, les MI sont des centrales versatiles parfaitement adaptées aux petits chantiers.

Pneumatic or electric or diesel, the MI plants are versatile perfectly adapted to small job sites.

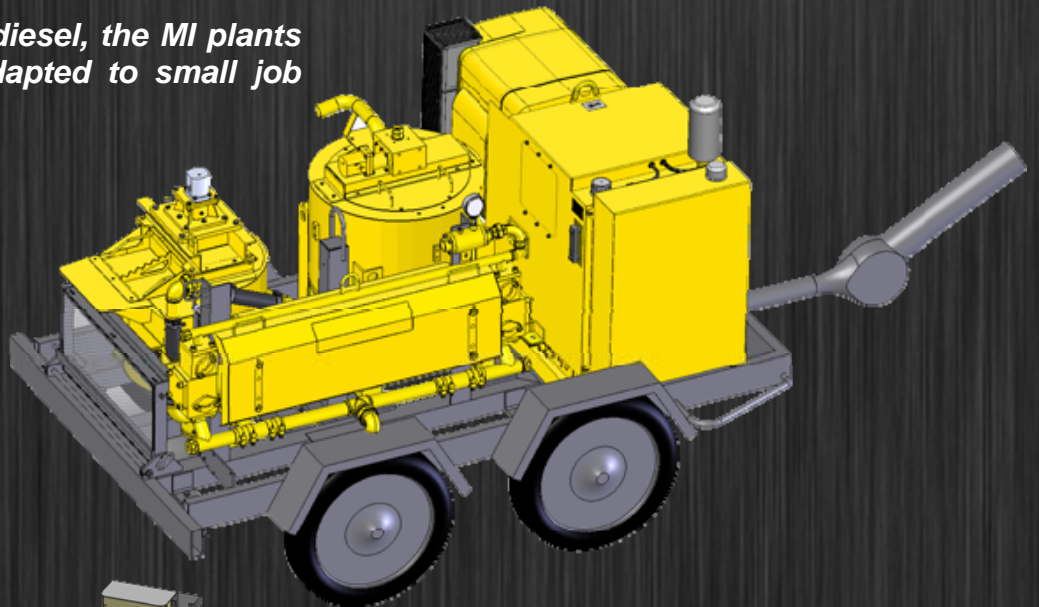

MI 120 D PH15/125/2x5

Sur skid / on skid :

L : 2 500 mm
W : 2 050 mm
H : 1 700 mm
P : 2 100 daN

Sur remorque / on trailer :

L : 4 850 mm
W : 2 050 mm
H : 1 650 mm
P : 2 700 daN with trailer

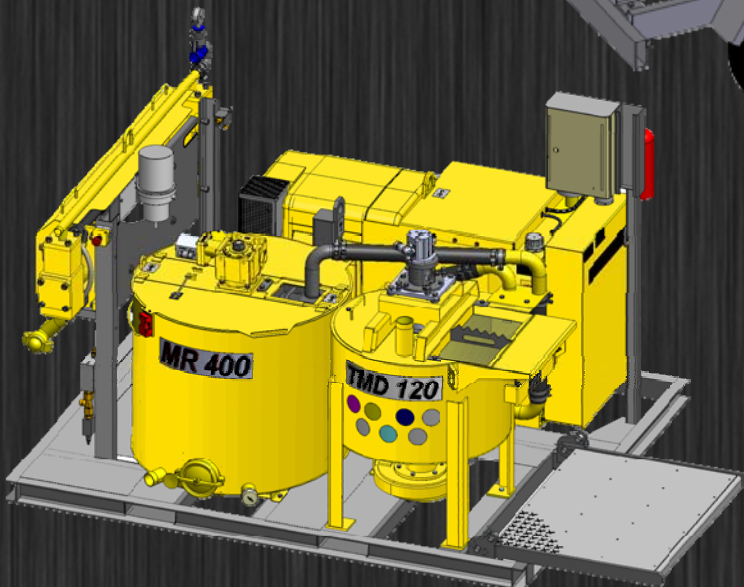

MI 100 P

Type de moteur	Pneumatique		Motor type	Pneumatic	
Mixeur :	Turbine		Mixer :	Impeller	
Energie – puissance	2 700 l/mn – 6 b – 2,76 kW		Energy – power	713 gal/mn–87 psi–3.7 hp	
Volume	100 l		Volume	26.4 gal (US)	
Injecteur	Piston PH5a		Grouting	Piston PH5a	
Energie - puissance	400 l/mn – 10 b – 4,5 kW		Energy – power	106 gal/mn–145 psi–6.1 hp	
Diamètre piston	50,8 mm	35 mm	Piston diameter	2 in	1 in 3/8
Pression maximum	40 b	84 b	Maximum pressure	580 psi	1 200 psi
Débit maximum	29 l/mn	9,5 l/mn	Maximum flow	7.6 gal/mn	2.5 gal/mn

MI 120 E PH5

Type de moteur	Electrique 400 v – 12 A		Motor type	Electric 400 v – 12 A	
Mixeur :	Turbine – 4 Kw		Mixer :	Impeller – 5.4 hp	
Volume	120 l		Volume	31.7 gal (US)	
Agitateur :	1,1 kW		Agitator :	1.5 hp	
Volume	300 l		Volume	79.2 gal (US)	
Vitesse de rotation	30 tr/mn		Rotating speed	30 rpm	
Injecteur	Piston PH5b – 3 kW		Grouting	Piston PH5b – 4.1 hp	
Diamètre piston	50 mm		Piston diameter	1.97 in	
Pression maximum	40 b		Maximum pressure	580 psi	
Débit maximum	12 l/mn		Maximum flow	3.2 gal/mn	

MI 120 D PH15/125/2x5

Type de moteur	Diesel – Hatz		Engine type	Diesel – Hatz	
Puissance	24,4 kW – insonorisé		Power	33 hp – soundproofed	
Réservoir à GO	85 l		GO tank	22.4 gal (US)	
Réservoir hydraulique	140 l		Hydraulic oil tank	37 gal (US)	
Mixeur :	Turbine		Mixer :	Impeller	
Moteur	Hydraulique		Motor	Hydraulic	
Volume	120 l		Volume	31.7 gal (US)	
Agitateur :			Agitator :		
Moteur	Hydraulique		Motor	Hydraulic	
Volume	400 l		Volume	106 gal (US)	
Vitesse de rotation	37 tr/mn		Rotating speed	37 rpm	
Injecteur	PH15.070	PH15.100	Grouting	PH15.070	PH15.100
	PH125	PH2x5		PH125	PH2x5

